

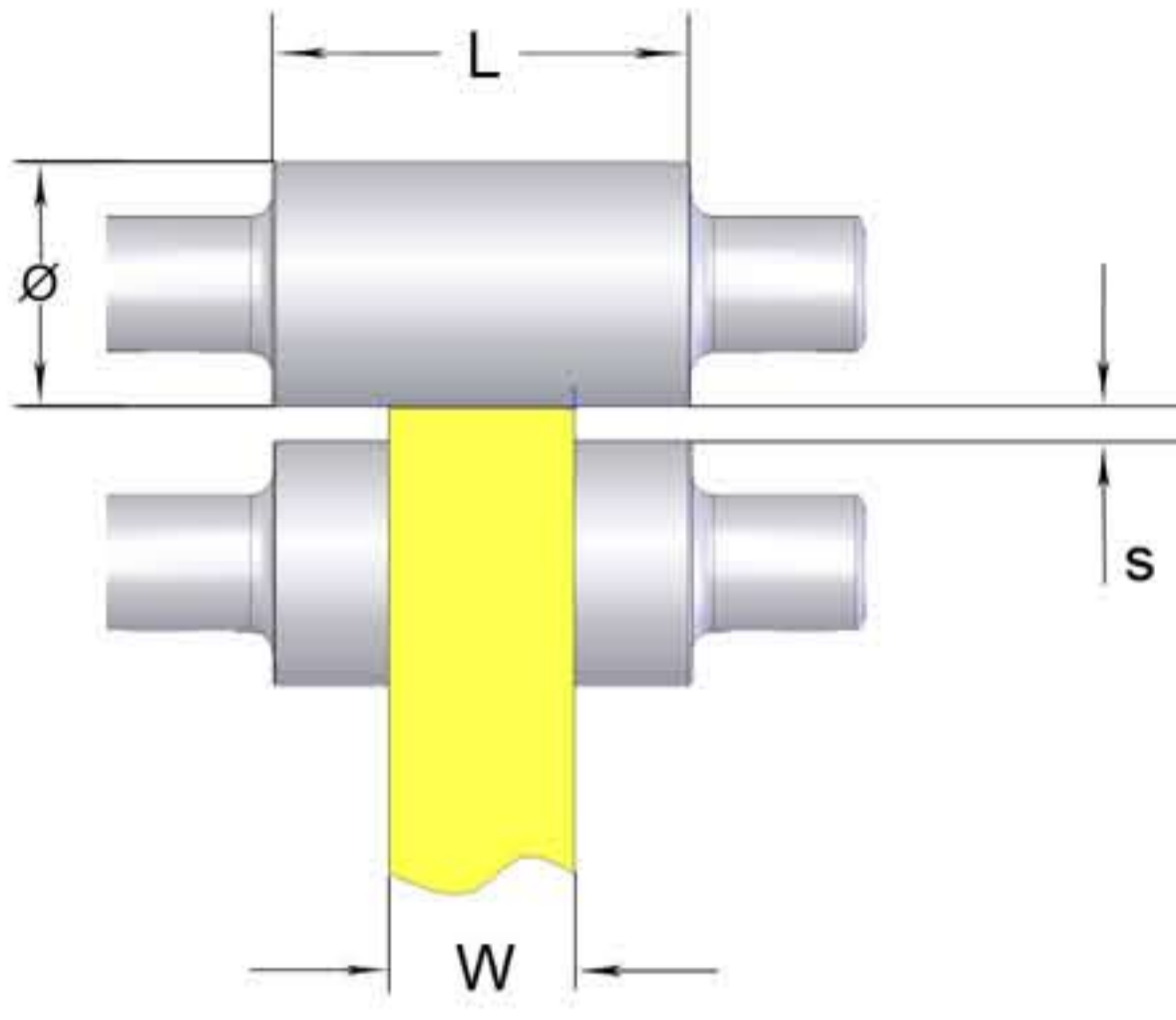

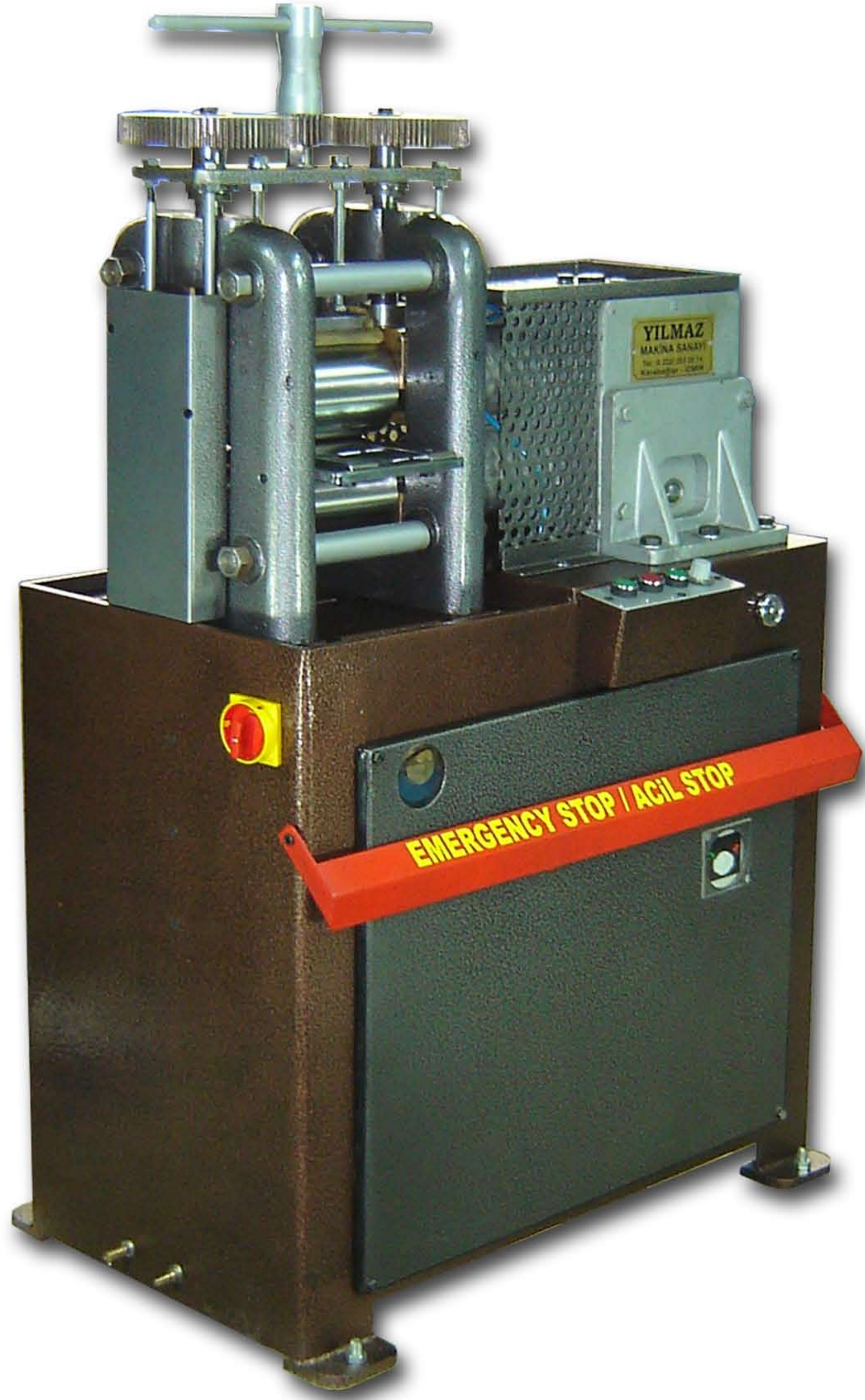

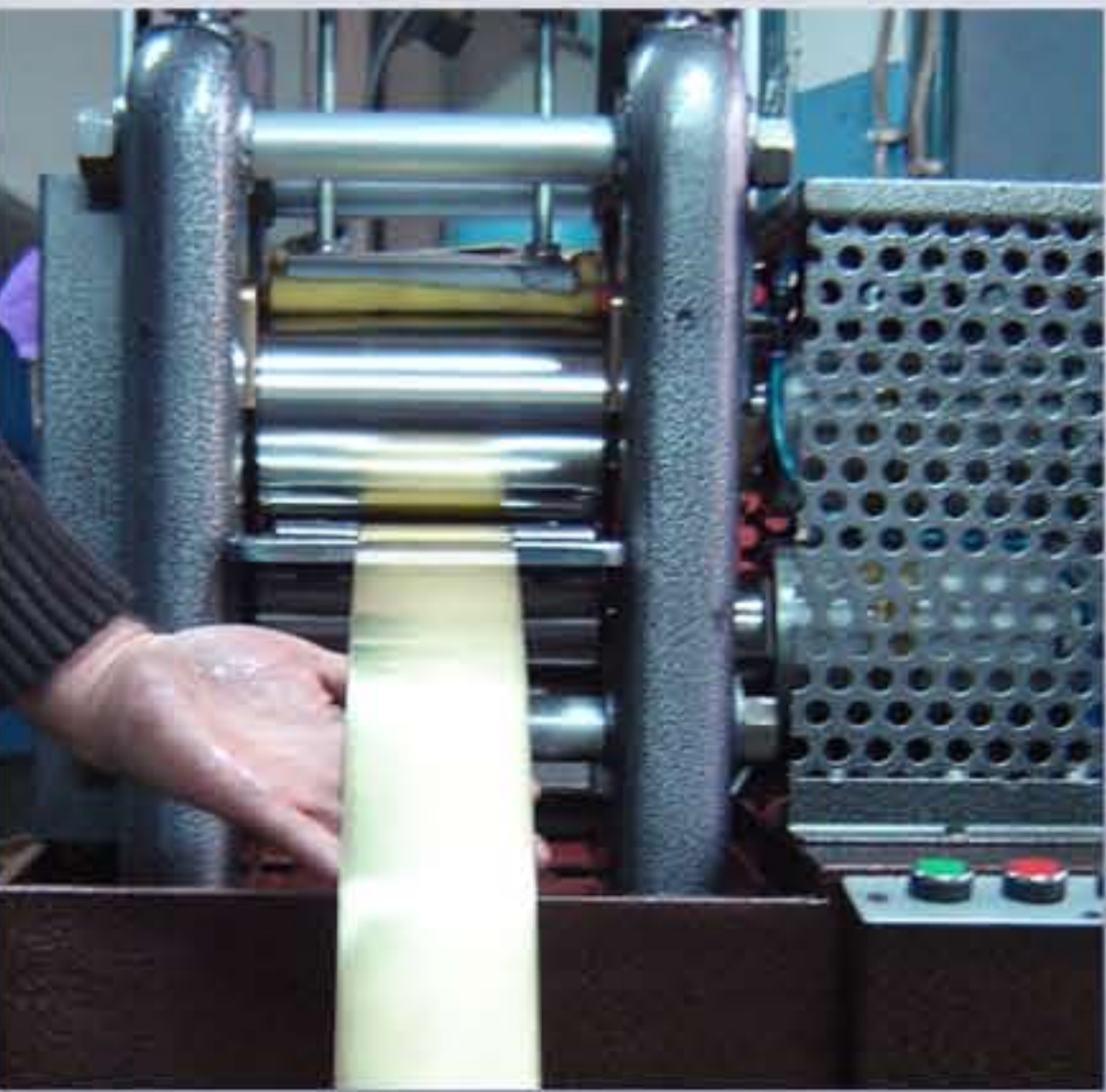

Master flat

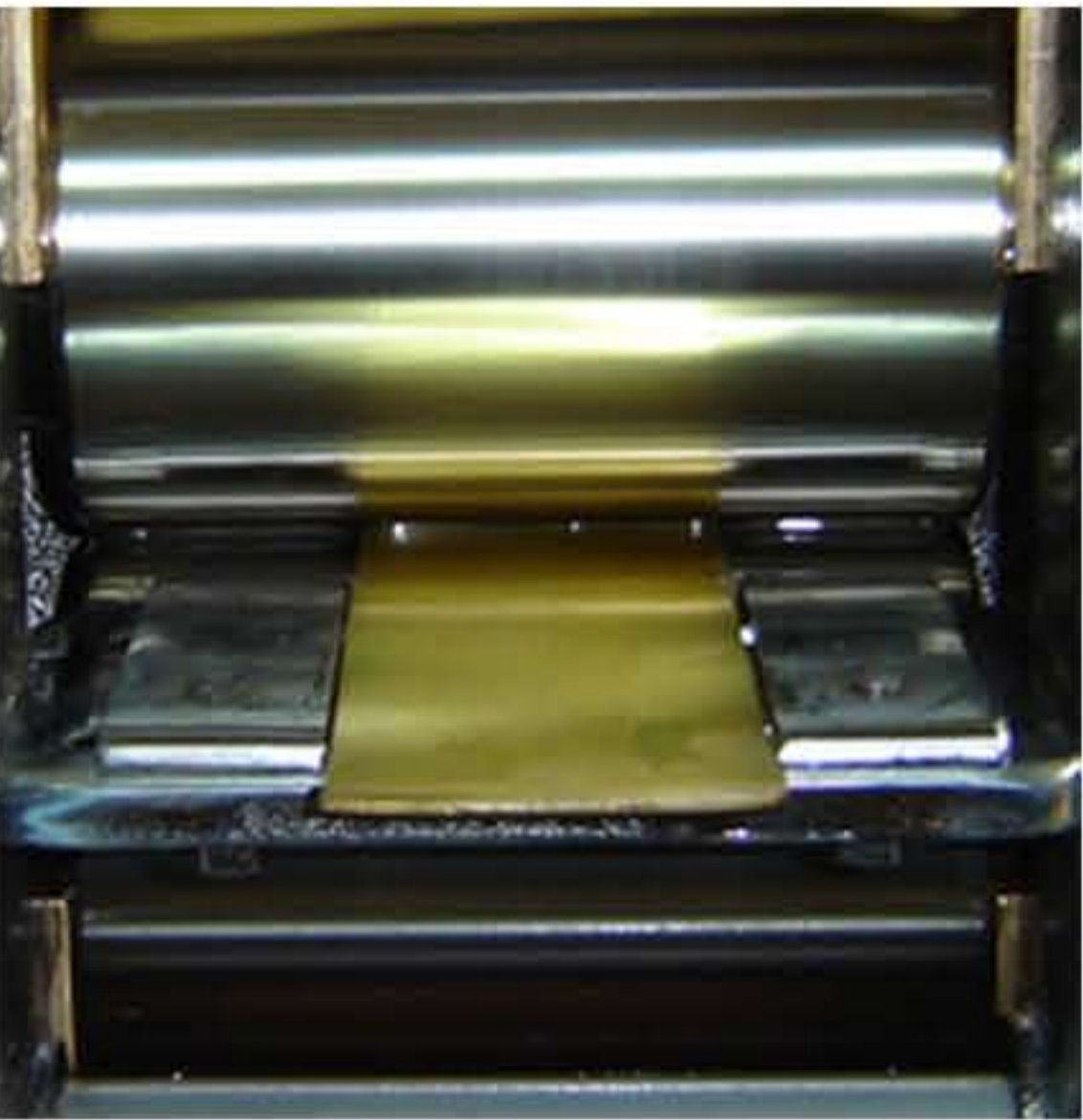
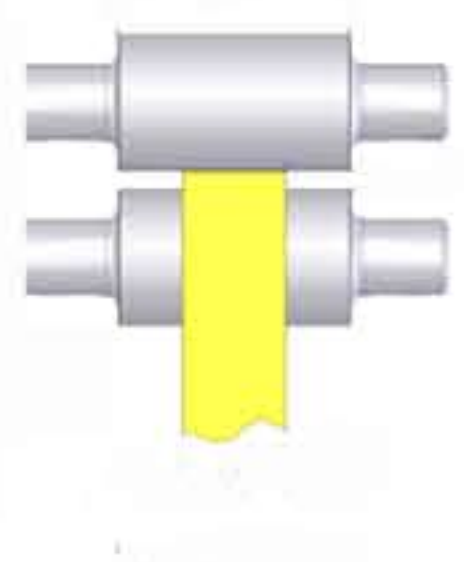

| | L | Ø | s | W |
|-------|-----|-----|----|----|
| MF140 | 140 | 120 | 30 | 80 |
| MF160 | 160 | 120 | 30 | 80 |
| MF180 | 180 | 120 | 30 | 80 |
| MF200 | 200 | 120 | 30 | 80 |



| Code | Kod | MF | |
|---|--|--|----------------------------|
|  | Rollers diameter | Merdanelerin çapı | 120 mm |
| | Rollers width for plate | Düz merdane genişliği | 120/160/180/200 mm |
| | Maximum rolling thickness | Maksimum haddeleme kalınlığı | 30 mm |
| | Maximum rolling width | Maksimum haddeleme genişliği | 80 mm |
| | Rollers hardness | Merdanelerin sertliği | 62-64 HRC |
|  | Lubrication system | Yağlama sistemi | ✓ |
|  | Internal cooling system | İçten soğutma sistemi | ✓ |
|  | Electrical power | Motor gücü | 5.5 kW |
| | Voltage | Gerilim | 380V three phase |
|  | Variable frequency control device, Emergency stop, Electrical breaking system and Digital speedometer. | Hız kontrol cihazı, Acil stop Elektrikli firen sistemi ve Dijital hız göstergesi | ✓ |
|  | Transmission to the rollers | Kaplin sistemi | Double oldham/Çift çıkışlı |
| | Gears | Dişliler | Hardened/Sertleştirilmiş |
| | Winding reels | Sarma makaraları | Optional/Opsiyonel |
| XYZ,G | Dimensions and weight | Boyutlar ve ağırlık | 80 x 45 x 140 cm 470 kg |